



Corporate Flow



Illustration



Image Editing



Automation



Web



Text Effects

# Canvas Tips and Techniques



Copyright © 1995-2005  
ACD Systems of America, Inc.

Protected by the copyright laws  
of United States and Canada  
and by international treaties.

## Using Dimensions in Canvas

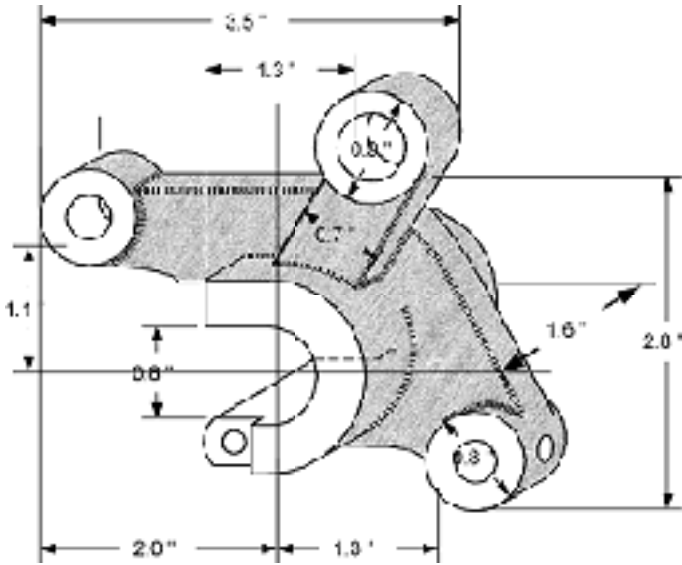

### Using Dimensions in Canvas

Learn how you could easily add formatted dimensions to documents with the Canvas Dimensioning Tools. These tools could be used to measure horizontal, vertical, oblique, and perpendicular distances. You could also measure diameters, radii, angles, areas, and perimeters.

In the following exercise, we will go over some of the basics for using the Dimensioning Tools, customizing the dimensions, changing properties, and saving your setting.

### Preparing the Document

We'll start this exercise by opening the Canvas file to which we want to add a dimension.

For this example, we will use an illustration of a automotive double-wishbone front suspension.

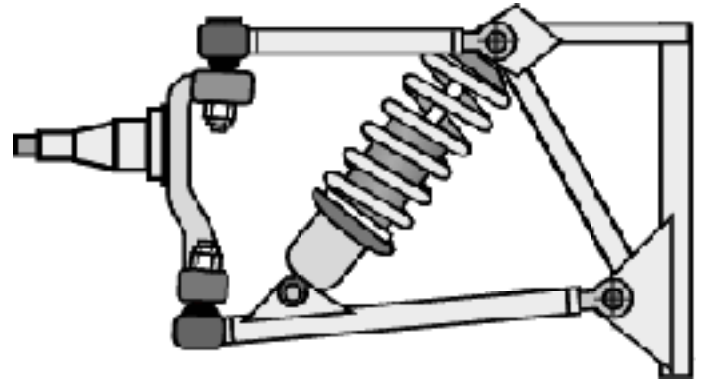

### Step 1

Select a Dimensioning tool from the Toolbox. There are 17 Dimensioning tools to choose from; however, for this example we will use the Horizontal Dimensioning tool.

**Tip:** It is good idea to drag the palette away from the Toolbox to keep it open while you work.

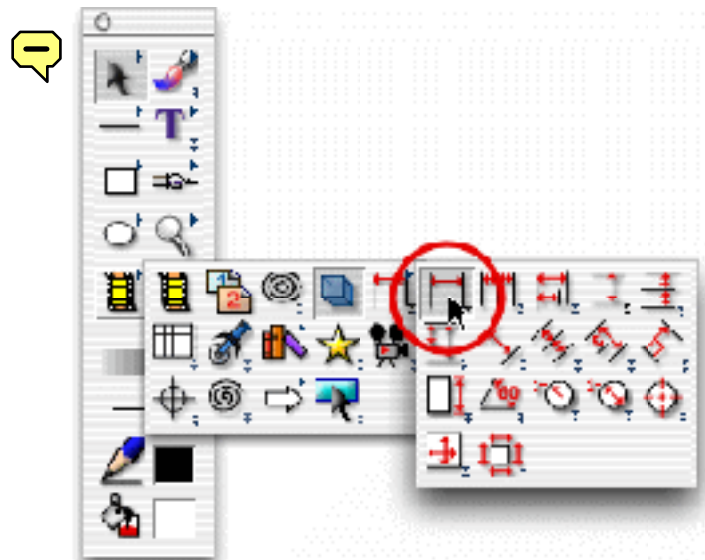

## Using Dimensions in Canvas (Continued)

### Step 2

#### Customizing the Dimensioning Tool

Double-click on the Horizontal Dimension tool to bring up the Dimensioning dialog box.

Using the Dimensioning dialog box, you could customize measurement units, scale, arrow position, tolerance text, and other settings for dimensioning objects. Let's take a look at some of the options.

**Dimension type:** Choose the type of dimension you want to configure. There are four different types of dimension type to choose from:

- **Angular:** use for angles.
- **Radial:** use for radius, diameter, center.
- **Linear:** use for horizontal, vertical, side, horizontal baseline, vertical baseline, horizontal, chain, vertical chain, Perpendicular.
- **Object Info:** use for area or perimeter.

For this exercise, we will use Linear type dimensions.

In the **Style** area, use the check boxes to modify the settings for arrow placement, text position, and text framing. For our example, we want our arrows inside and the text centered.

Next, choose the text alignment method in the **Text Display** drop-down menu. Choose Horizontal.

**Leading Character** is used to configure the leaders for linear and radial dimension object. Select None.

**R,D symbols** configure the radius and diameter symbols for radial dimension objects. This drop-down menu only becomes active if Radial is selected as the Dimension type.

The **Precision** option tells Canvas to use fractions or the specified number of decimal places in the dimension text.

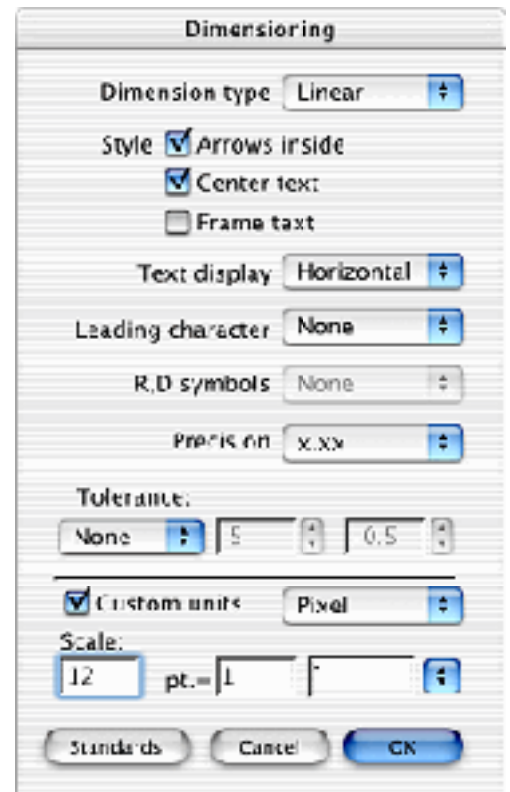
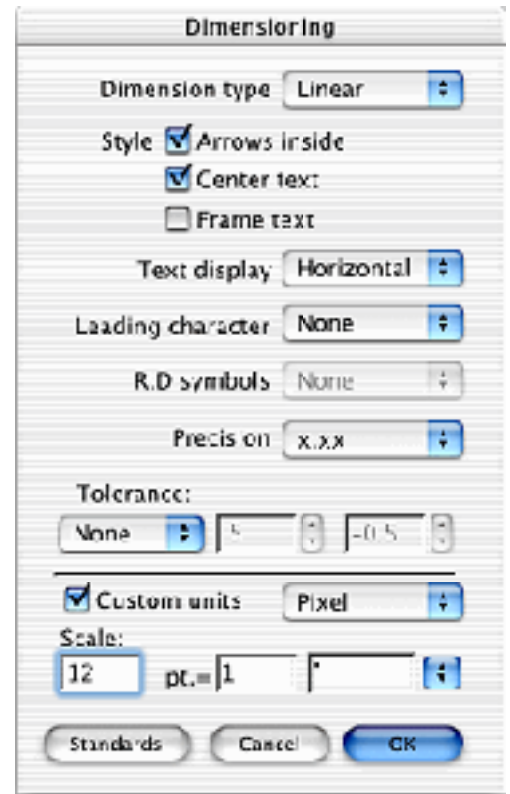

## Using Dimensions in Canvas (Continued)

**Tolerance** is used to specify the format of tolerance data in the dimension object.

Next, select the **Custom Units**. Change the units to pixels.

For the Scale, we want 12 pixels to equal one inch. When you are done making your changes, click OK.

### Step 3

#### Adding a dimension to an illustration

To begin dimensioning first position the pointer and click as directed by the prompt. In this example we want to illustrate the length of the lower suspension a-arm. So the first thing we do is click our cursor on the center of the lower ball joint as prompted.

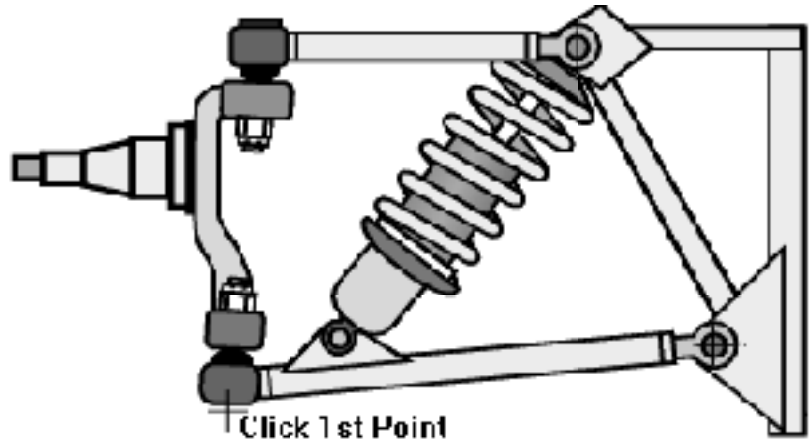

Next, click on the second point as prompted to complete the measurement.

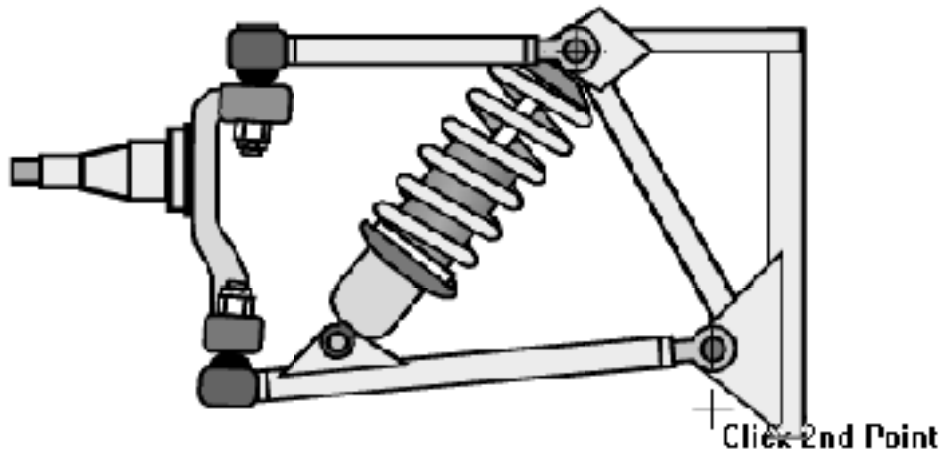

When the anchor prompt appears, drag the pointer away from the measurement points. As you drag away, you notice lines extending from the measurement points.

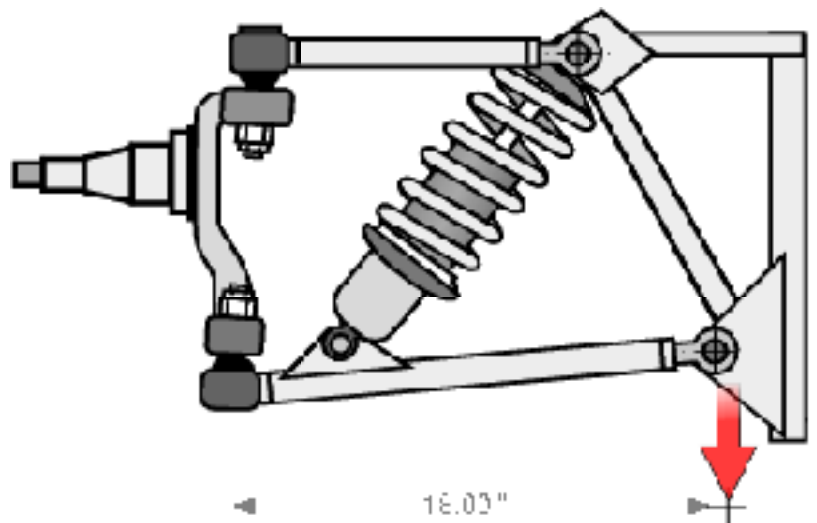

## Using Dimensions in Canvas (Continued)

When you are satisfied with the anchor's position click the cursor once to anchor it in place.

**Note:** You may double-click on the dimension object to edit or customize it via the Dimensioning dialog box.

### Additional Tips:

If you want to use industry standard settings for dimension objects, click on the Standards button in the Dimensioning dialog box. You can choose from several industry standards in the Current standard menu.

If you customize the settings in the Dimension Standards dialog box, you can save your settings as a custom standard. Save your custom settings by selecting the Dimension Menu icon at the bottom left corner of the Dimension Standards dialog box. This will display a menu for saving and deleting dimension standards.

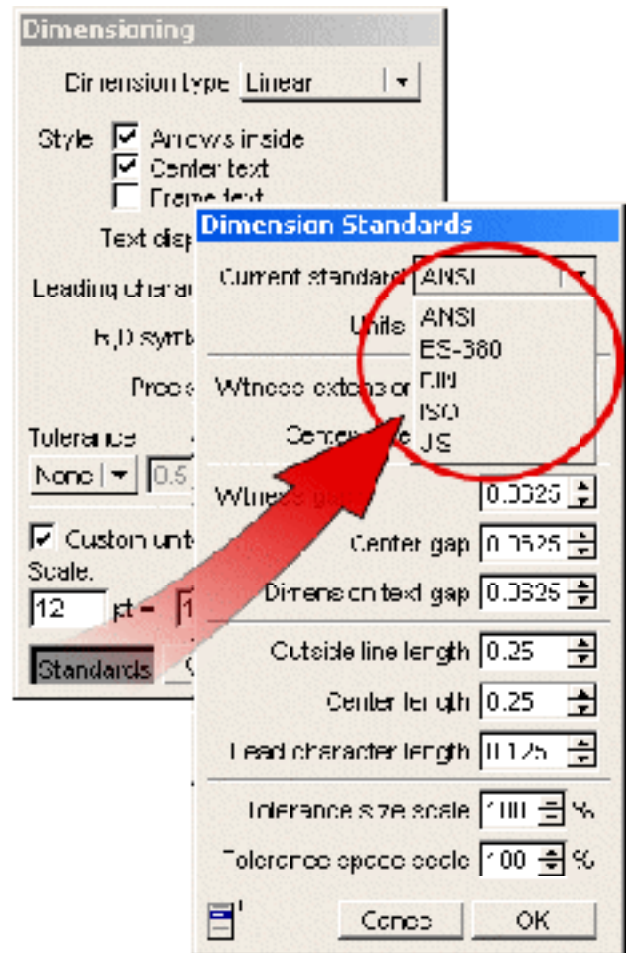
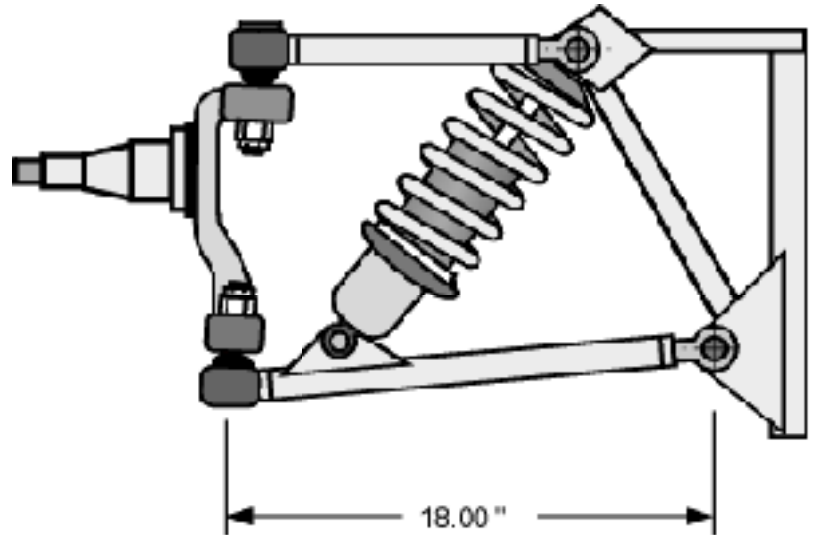

To save a setting as a new standard, choose "Save settings as", type a name for the new custom standard in the dialog box and click OK.

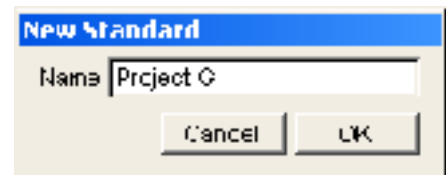

## Using Dimensions in Canvas (Continued)

The new custom standard now appears in the Current Standards drop-down menu.

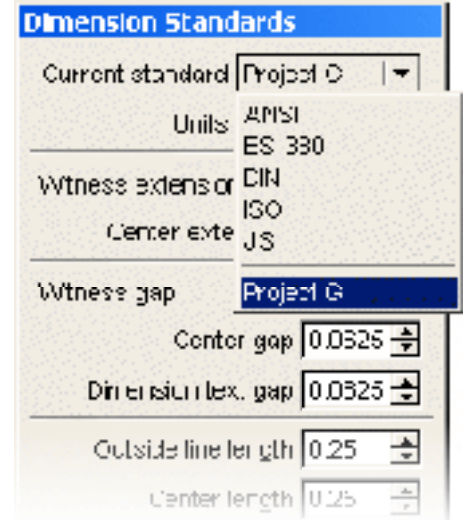

### More Tips:

Changes could also be made to the current ink, stroke, and text by selecting the dimension and using the appropriate palette.

Also, since dimensions don't attach to the objects they measure, dimensions don't change when you resize the objects. You can group a dimension object and the object that it measures. However, when you do this and then resize the object, the dimension changes accordingly. To group an object and a dimension object just select them and choose Object > Group.

This was just a brief introduction to dimensioning in Canvas, there are many other dimensioning tools and options.

